

---

# DOWELFORM

## DOWELBAR SLEEVE SYSTEM

---

### PRODUCT DESCRIPTION

---

CORKJOINT Dowelform is a two part dowelbar sleeve system comprising a rigid PVC dowelbar sleeve and a reusable rigid PVC nailing plate. Dowelform is suitable for use with 20mm, 25mm and 32mm round or square dowelbars.

Dowelform allows for longitudinal movement as well as lateral (sideways) movement of the dowelbar for maximum joint performance. Compressible fins on either side of the sleeve enables the dowelbar to move sideways and locate the dowel centrally. (Refer Fig. 1) the end cap has an inbuilt 20mm shear pin to allow for expansion of the concrete of up to 20mm.

Dowelform allows your dowelbars to be parallel to the subgrade and properly aligned. You can also achieve lateral (sideways) movement of +/-10 mm for round and square bars which will help to reduce internal stresses on the concrete.

Dowelform allows the engineer to specify dowels in both directions where transverse and longitudinal joints meet as all joints are now free to move independently of each other. (Refer Fig. 2 & 3)

### ADVANTAGES

---

- Suitable for use with round and square dowels
- Allows for 20mm of longitudinal expansion movement of concrete
- Allows lateral (sideways) movement of all dowels
- No misaligned dowels to restrict joint movement
- Can prepare formboards with nailing plates prior to installation
- Eliminates drilling holes through formwork
- No dowelbars protruding from concrete
- Nailing plates are re-usable
- No need to coat dowelbars with bitumen, grease or de-bonding agents
- No need to apply an expansion cap on end of dowelbar
- Dowelled joints possible in all directions
- Suitable for post tensioning

Fig 1

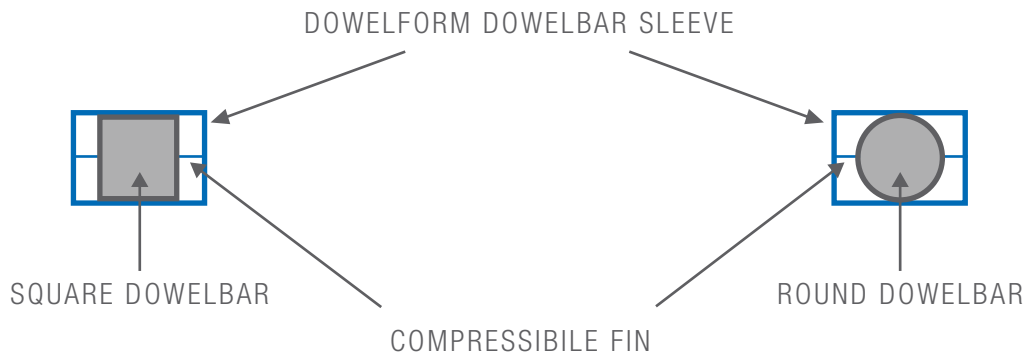

Compressible fins allow the dowelbars to move sideways and to help locate the dowelbars centrally

Fig 2

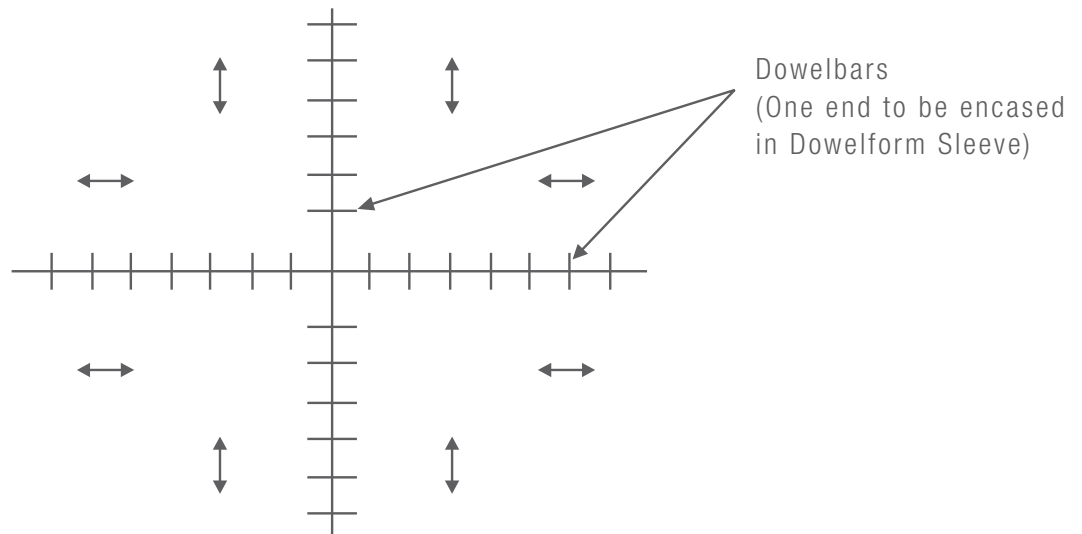

The use of Dowelform dowelbar sleeves allow the slabs to move in designated directions

Fig 3

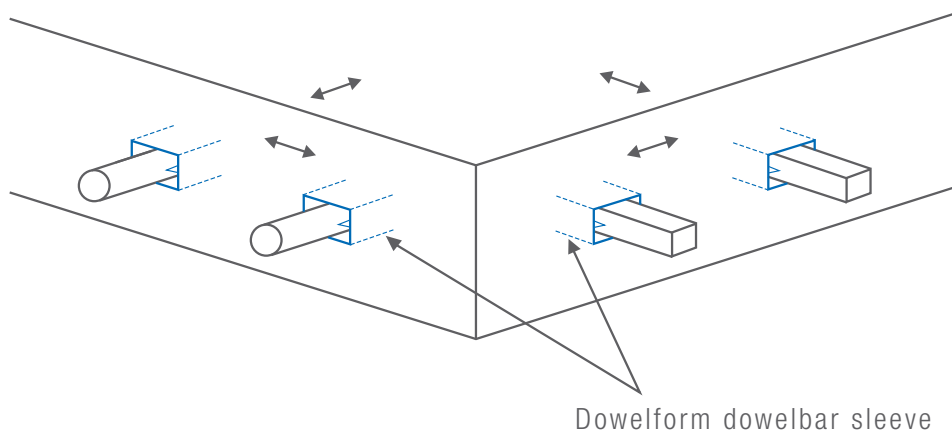

Dowelform allows the engineer to specify round or square dowelbars in designated directions

## AREAS OF APPLICATION

Construction joints, contraction joints, expansion joints in industrial buildings, roadways, curved joints, post tensioned slabs and new to existing concrete.



## AVAILABLE SIZES

- 20mm cut to length to suit
- 25mm cut to length to suit
- 32mm cut to length to suit

Dowelform can be made to suit the required length of dowelbar. For post tensioning, indicate movement required. Check with your design engineer to confirm suitability.

## POST TENSIONING

Dowelform is ideal for use in post tensioning slabs. Units can be made up to allow for extra movement that may be required. For post tensioned applications, the engineer should indicate the amount of movement required.

## GENERAL INFORMATION

It is well known that one of the most common causes of joint failure in concrete joints is the misalignment of dowelbars, if dowelbars are not aligned correctly in the concrete, they can restrict movement of the slabs and cause cracking around the joint. As concrete expands and contracts, dowelbars should be allowed to slide in and out of the concrete free from any resistance. Dowelbars are specified by engineers to transfer shear load across expansion and construction joints for poured in-situ concrete. The size, spacings and location of the dowelbars should be detailed by the engineer.

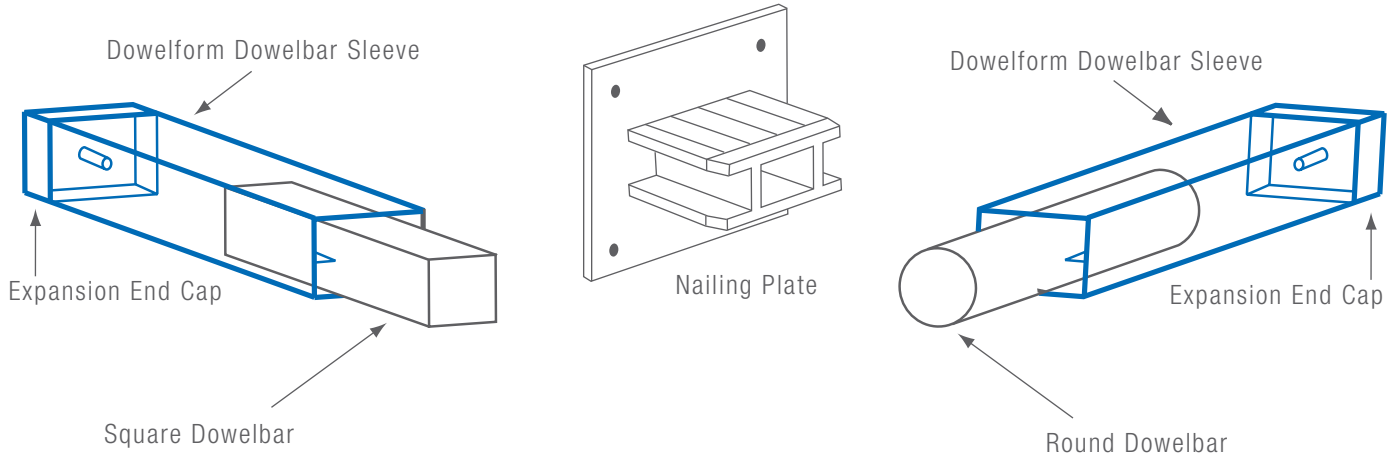

## WRITTEN SPECIFICATION

Dowelbar sleeves where shown on the drawings shall be CORKJOINT 'Dowelform' dowelbar sleeves (insert size required) as supplied by CORKJOINT. The dowelbar sleeve shall be capable of accommodating 20mm of longitudinal expansion and +/-10mm of lateral (sideways) movement and are to be installed in accordance with the engineers recommendations.

## INSTALLATION PROCEDURES

1. Use a stringline to indicate height for Dowelform dowelbar sleeve on formboard, mark the centre spacings of dowelbars required along stringline.
2. Nail Dowelform nailing plate to formboard at the required/specified spacings.
3. After steel reinforcement is in place, slide the Dowelform dowelbar sleeve over the nailing plate. Extra support may need to be positioned under ends of Dowelform for long dowelbars.
4. Pour concrete being careful to ensure vibrator does not come into contact with dowelbar sleeve. When formboards are removed, the nailing plates stay attached and are ready for your next use.

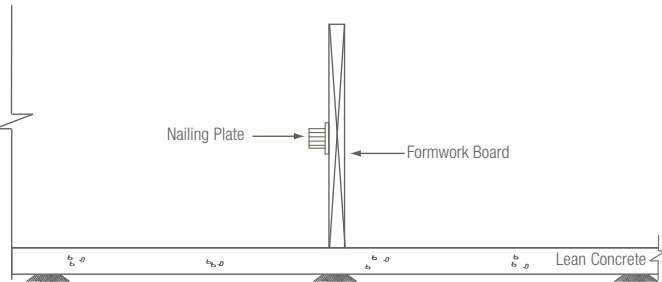

A. Secure the nailing plates with nails, at the required spacings, onto the face of the formwork that is accepting the 1st pour of concrete.

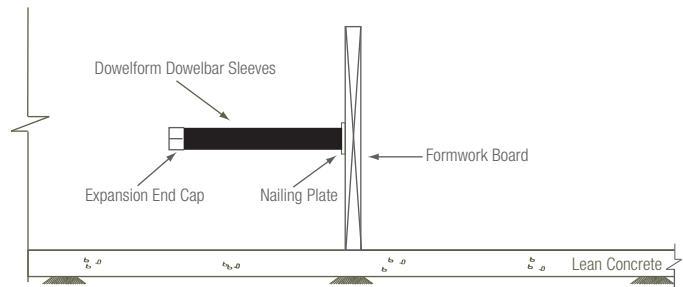

B. Insert the Dowelforms onto the nailing plates. If Dowelform is a long length, place a bar chair under the end, to help secure it during concrete placement.

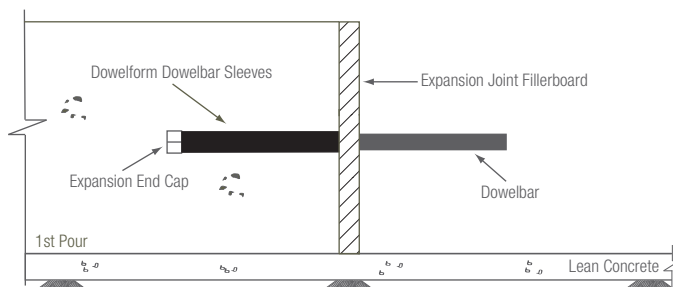

C. Once formwork is removed, place expansion joint fillerboard against the face of the 1st pour of concrete. The application is now ready for 2nd pour to take place.

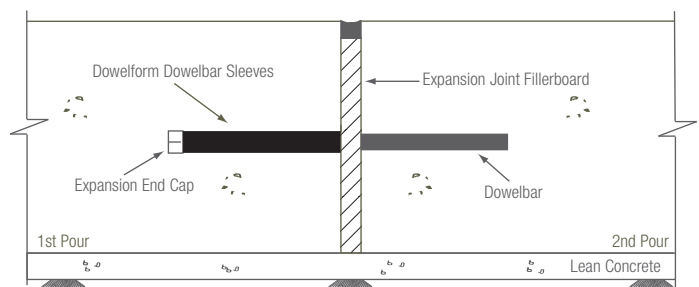

D. Add joint sealants if and when required.

The information and the recommendations relating to the application and end use of this product are given in good faith and are based on the information provided by the manufacturer of the product and / or the Company's current knowledge and experience in connection with the product when properly stored, handled and applied under normal conditions and no liability of final function at the job site is assumed. In practice, the differences in materials, substrates and actual site conditions are such that no warranty in respect of merchantability of or fitness for a particular purpose, nor any liability arising out of any legal relationship whatsoever, can be inferred either from this information, or from any written and / or oral recommendations, or from any other advice offered by the Company. No responsibility or liability by the Company will be accepted for misuse, misreading or derivation from the recommended guidelines in respect of this product and the user shall determine the suitability of the product for his intended use and assume all risks and liability in connection therewith. The information contained in this brochure may change at any time without notice.

Effective Date: 01 June 2011

**CORKJOINT (MALAYSIA) SDN BHD** 383102-H  
 Lot E/23117, Jalan 5/32A, Off Batu 6 1/2 Jalan Kepong  
 52100 Kuala Lumpur, Malaysia  
 Tel +603 6250 9630  
 Fax +603 6250 9650

**CORKJOINT (SINGAPORE) PTE LTD** 200716724-K  
 50 Tagore Lane #03-11, Entrepreneur Centre  
 Singapore 787494  
 Tel +65 6455 9331  
 Fax +65 6455 8535